

EAV Wiring Diagrams

Fail Safe and Fail Secure

TB0055 - January 2022



EAV Entrance Door Lock Wiring diagram for Fail Safe

This schematic is a guide only, a qualified Electrical Engineer should be consulted.

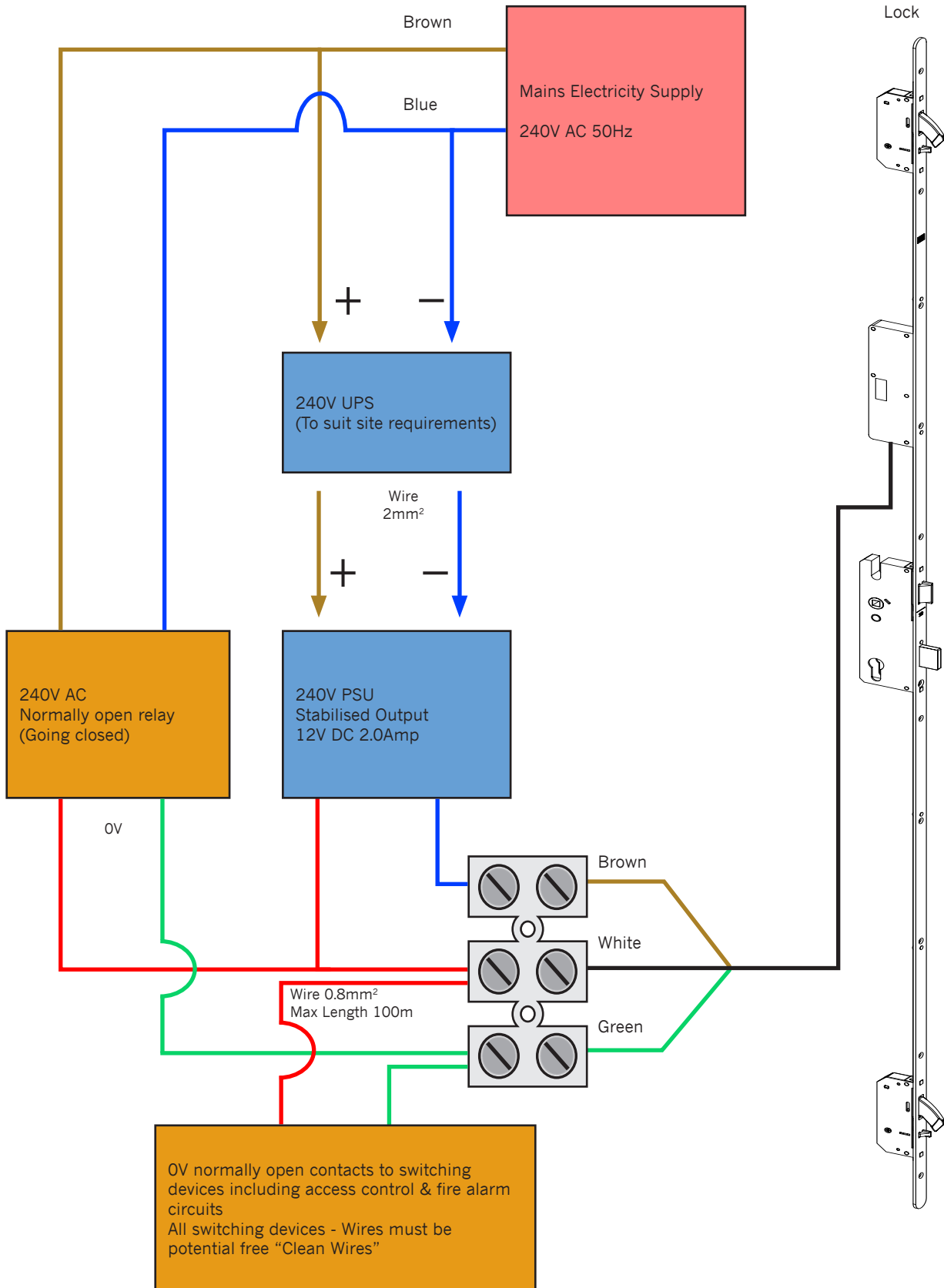

EAV Entrance Door Lock Wiring diagram for **Fail Secure**

This schematic is a guide only, a qualified Electrical Engineer should be consulted.

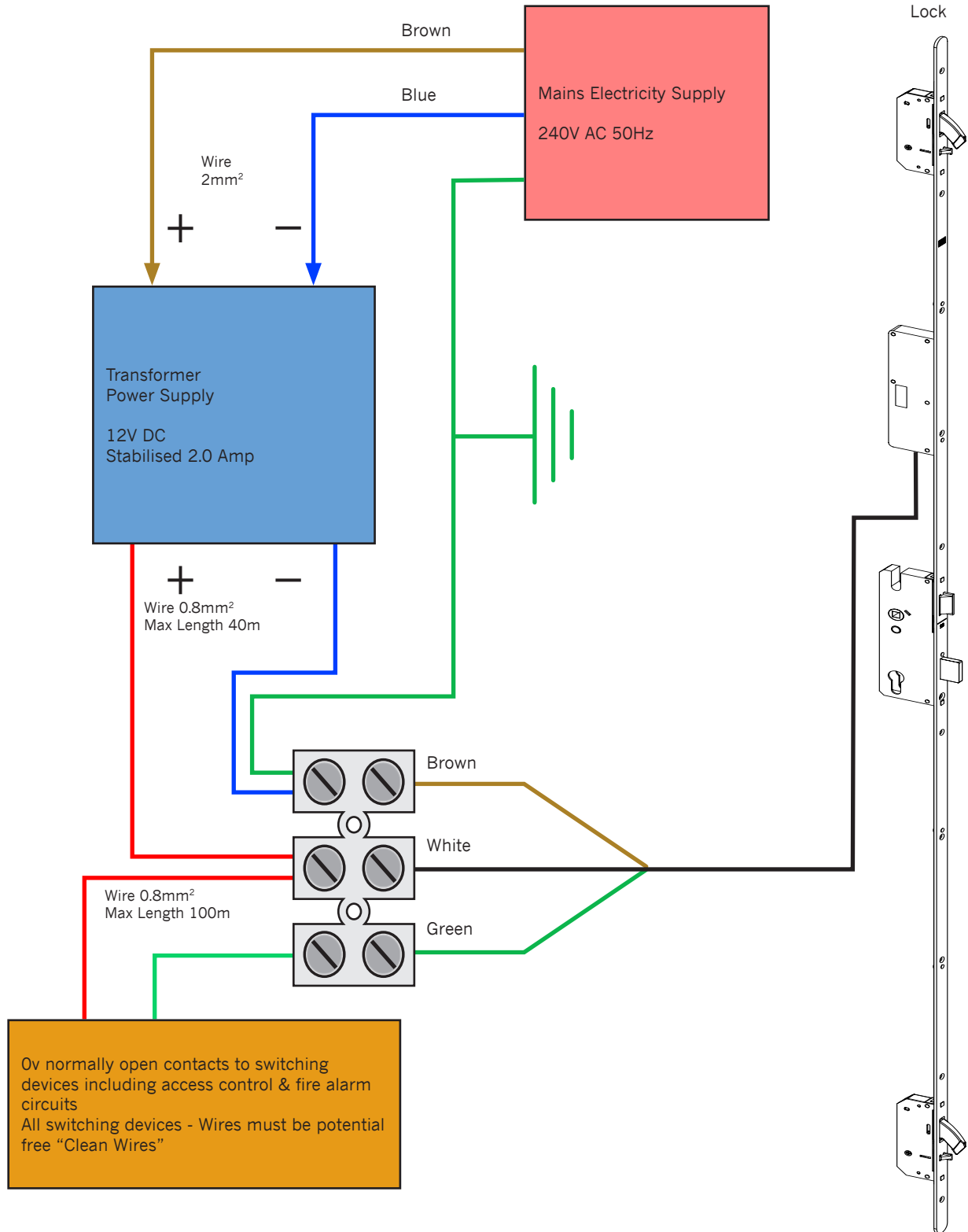

EAV Entrance Door Lock Wiring diagram for SBD Compliance

Secure for 6 hours after which fail safe.

This schematic is a guide only, a qualified Electrical Engineer should be consulted.

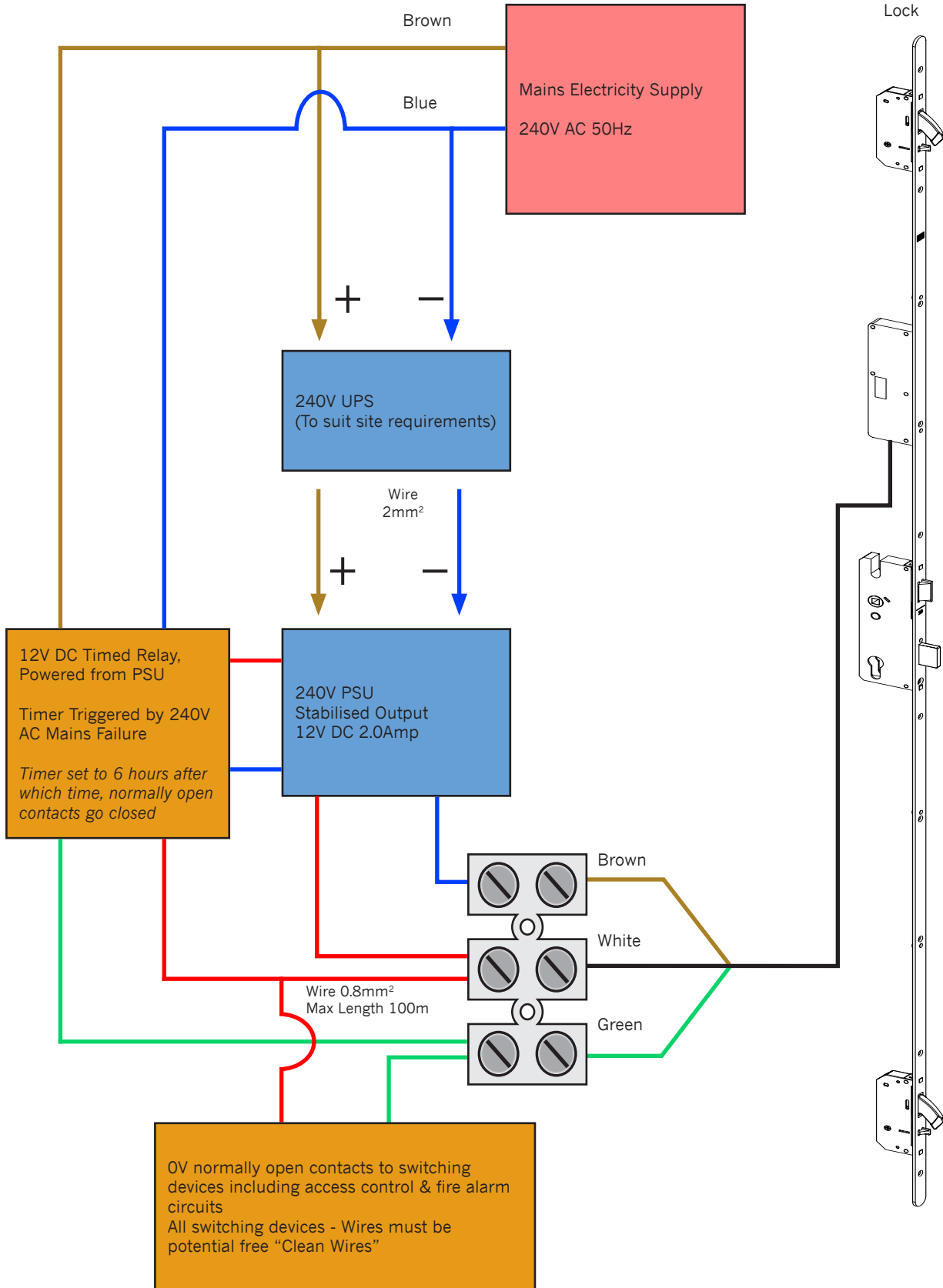

Winkhaus UK Ltd

2950 Kettering Parkway, Kettering,
Northants NN15 6XZ
Tel: +44 (0)1536 316000

www.winkhaus.co.uk